

CK tank 10

Description:

Cylindrical vessel with conical bottom part in angle of 60° installed on three adjustable feet, usable capacity 1 000 l.

This vessel is designed for primary and final fermentation of beer.

Accessories:

Oval manhole 340*420 mm	1.4301
Sanitary rotating shower with piping DN 25 mm	1.4301
Level indicator DN 15	1.4301
Underpressure/overpressure armature DN 20	1.4301
Supply and discharge flap valve DN 32	1.4301
Duplex jacketing of conical part, clearance 12 mm	1.4301
Duplex jacketing of cylinder, clearance 12 mm	1.4301
Insulation polyurethane, clearance 50 mm	
Insulation covered with metal sheets 1 mm thick, ground surface	1.4301
Upstream armature DN 32	1.4301
Electromagnetic valve DN 20 for cold water supply	230V 50 HZ
Blind flange DN 32, 1 piece	1.4301

Upstream armature: stop valve DN 20, immersed in transparent tank
manometer DN 60
back ball valve for additional pressurisation DN 15

Operating conditions:

Maximum operating temperature	80°C
Minimum operating temperature	-15°C

Parameters

Overall height	2 350 mm
Diameter(with insulation)	1 100 mm
Overall capacity	1 271 l
conical part	227 l
cylindrical part	981 l
Ached bottom	63 l
Empty weight	278 kg

Warranty:

CK tank	36 months
Electromagnetic valve DN 25	24 months
Upstream armature	36 months

Transport

This tank is usually shipped in horizontal position, fixed on special framing.
Ground-plan frame dimensions: 2300*1000 mm

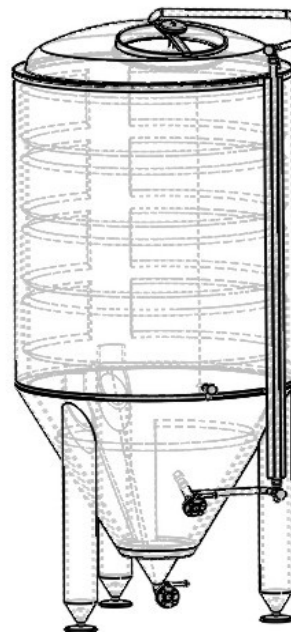

OPERATION

DOUBLE-ACTING VALVE

1. UTILISATION

This double-acting valve is intended for utilisation in equipment and spaces working with operating overpressure in order to prevent them against exceeding its permissible limits. Such equipment shall be protected also against possible implosion provided its operating medium is pumped out because it allows air suction inwards.

2. ASSEMBLY

This double-acting valve can be installed in any position, however, it is mounted usually in a vertical position on a vessel top part, screwed in its threaded counterpart on the vessel, under use of proper thread type seal, usually with Teflon packing strips.

1. Body
2. Tube
3. Plate
4. Underpressure plate
5. Food seal EPDM
6. Bolt M6
7. Nut M6
8. Overpressure spring
9. Underpressure spring
10. Adjusting bolt
11. Locking washer

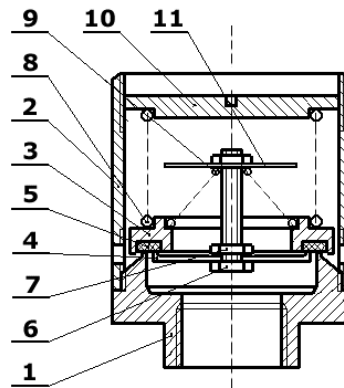

3. OPERATION

Once in two weeks carry out a functional test of the sealing plate by lifting it with a thin rod, e.g. a screwdriver. Should particular sealing surface be leaky and untight, so it is necessary to dismantle the valve and to overlap affected areas by fine grinding compound No. 600 on even surface (glass).

4. WORK SAFETY

Since it is an opened check valve, it is necessary to position it so that its contingent opening and air discharge cannot cause injury of persons. Its distance from attendants should be depending on preset opening overpressure values, anyway at least 1m. We do not recommend installing it at persons head height. Should gases, other than air, be used, it is necessary to insure perfect ventilation of affected spaces.

PRESSURE REGULATORS HPZ1 AND HPP1

1. UTILISATION

This pressure regulator is intended for utilisation in all equipment where observance and regulation of preset pressure limits are required. It is used usually in brewery where diverse pressure limits for particular manufacturing phases should be preset and kept.

2. INSTALLATION

This pressure regulator should be solely installed in a vertical position with its adjusting screw upwards. The threaded-type regulator should be screwed in its counterpart on the vessel under use of applicable thread type seal, usually with Teflon packing strips.

NOTE: Just before welding, the weld-neck regulator, type HPP1, should be dismantled to particular pieces and then it is necessary to weld its body only, see figure, item No. 1. Otherwise, its plastic plate, gaskets and EPDM tapered plug could be damaged.

1. Body
2. Counterpart
3. Taper plug
4. Adjusting screw
5. Spring
6. O-ring
7. Plate

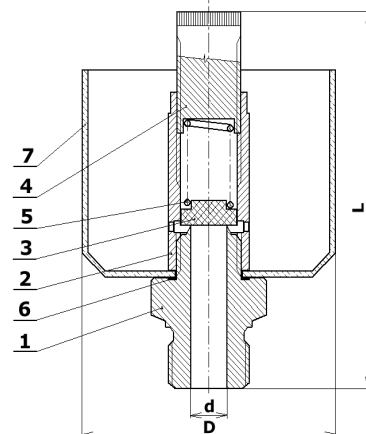

3. OPERATION

While in service these pressure regulators run nearly maintenance-free. In case the tapered plug remains closed for longer than 14 day it may get stuck to its valve seat. Therefore, once in two weeks carry out its functional test by lifting it with a thin rod without sharp edges, e.g. a little hook, or by sensitive loosening of the adjusting screw until inside overpressure opens the valve (slight fizzing noise or first bubbles in indication water).

4. WORK SAFETY

Since carbon oxide, generated in particular manufacturing phases, may leak through this pressure regulator into ambient free space, it is necessary to insure perfect ventilation of affected rooms.

5. WARRANTY CONDITIONS

Manufacturer's warranty lasts for 24 months after date of delivery. This warranty should be claimed in company's headquarters.

